

# AIR RECYCLING ASPIRATOR

HSKTHI

The Air Recycling Aspirator provides an efficient separation of light impurities from cereals. Three inlet options enable a standalone application as well as compatibility with a Milling Separator or a Scourer. Whether installed at the grain intake point or integrated into a cereal cleaning system, the machine creates significant savings in energy, space and maintenance.

## Features & Advantages

- Connectivity to the central ventilation system
- Efficient cleaning and separation process



↓ Front View

↓ Side View

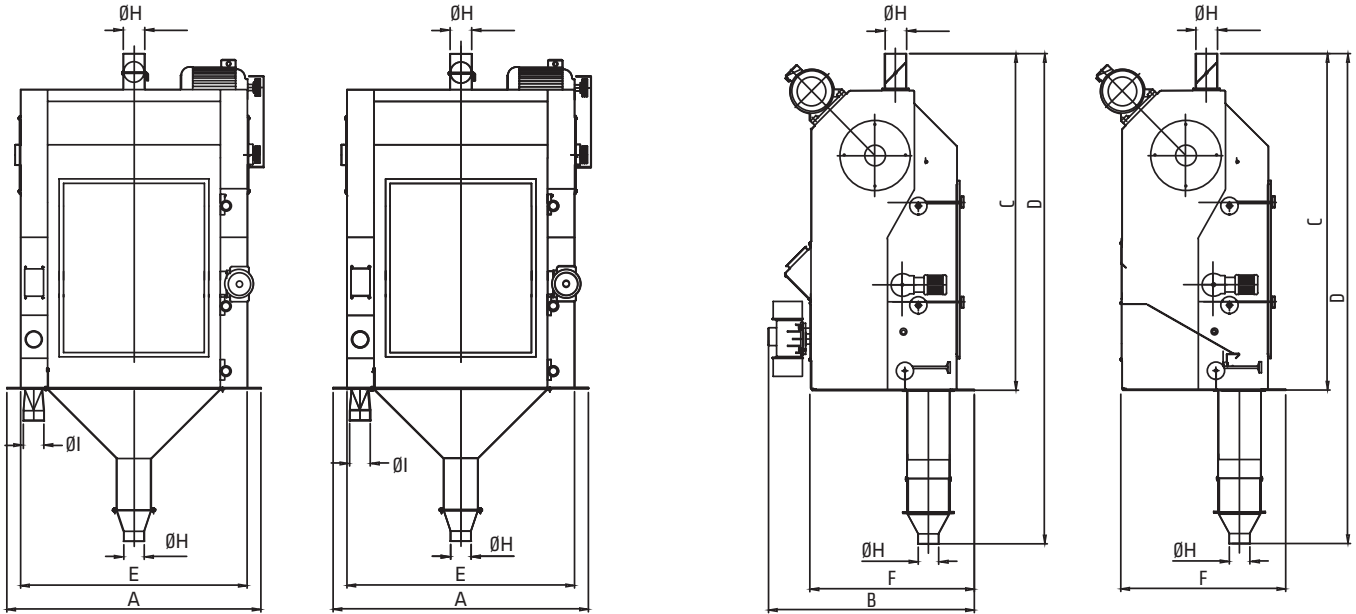

## Technical Features

Model	Capacity (TPH) Flour		Air Requirement(m <sup>3</sup> /min)		Weight (Kg)		Gross Volume (m <sup>3</sup> )
	Pre-Cleaning	Cleaning	Pre-Cleaning	Cleaning	Net	Gross	
HSKTHI 600	40	4-8	10	6	495	717	5.3
HSKTHI 1000	50	9-14	12	8	650	933	7.6
HSKTHI 1500	100	14-24	16	10	711	1,066	10.5

## Dimensions (mm)

Model	A	B	C	D	E	F	øH	øI
HSKTHI 600	1,080	1,177	1,945	2,535	920	947	120 150	120
HSKTHI 1000	1,480			2,829	1,320			
HSKTHI 1500	1,980			3,043	1,820			

\*Henry Simon reserves the right to change, delete, or otherwise modify the information which is represented without any prior notice.