

# FLOW BALANCER

## HSTFBI

---

Flow balancer is used to electronically measure the gravimetric flow rate of grain. This equipment mainly placed under the raw material and product silos for efficient blending process.

## Features & Advantages

---

- High accuracy and product flow rate
- Robust and high quality body
- Long life span



↓ Top View

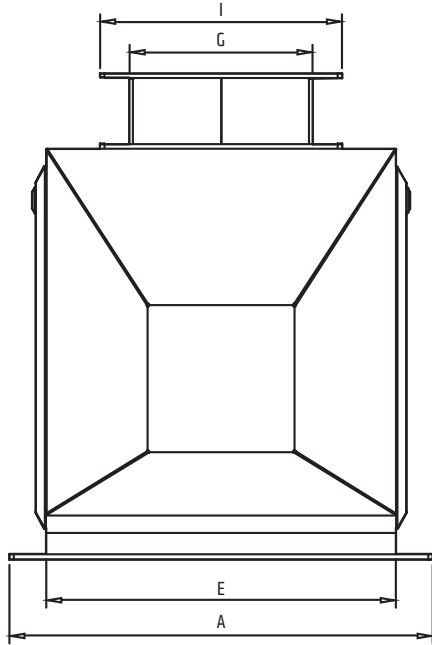

↓ Side View

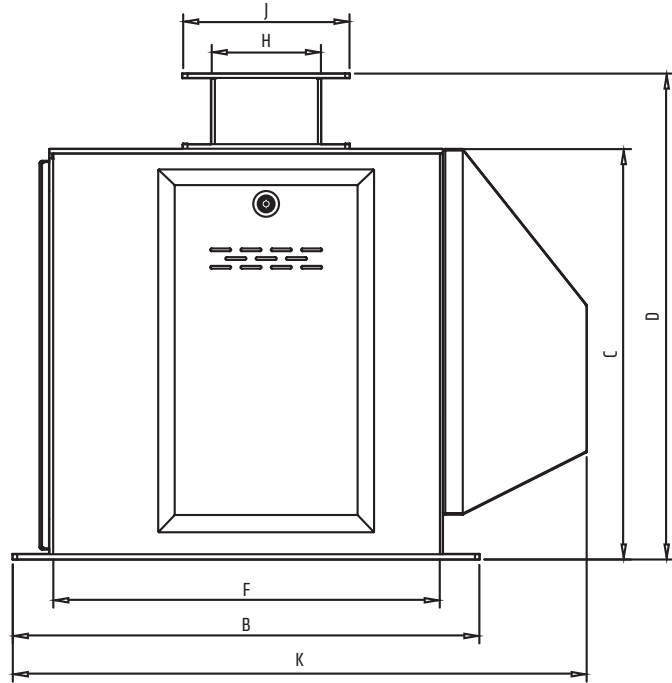

### Dimensions (mm)

Model	A	B	C	D	H	G	øJ
HSTFBI 30	350	700	594	650	240	295	150
HSTFBI 100	600		600			545	200

### Technical Features

Capacity (TPH) Wheat*	Weights (Kg)		Gross Volume (m <sup>3</sup> )
	Net	Gross	
30	150	198	0.3
50	200	260	0.5

\* Calculations are for flour

\*Henry Simon reserves the right to change, delete, or otherwise modify the information which is represented without any prior notice.