

# HSMPKA

# SLIDING GATE

- Sliding gate is used to allow or interrupt product flow, or change the flow direction to any desired terminal. It is generally placed under chain conveyors, tubular conveyors etc.

## FEATURES

- Compact Design
- Leakproof Structure
- Trouble-Free Operation

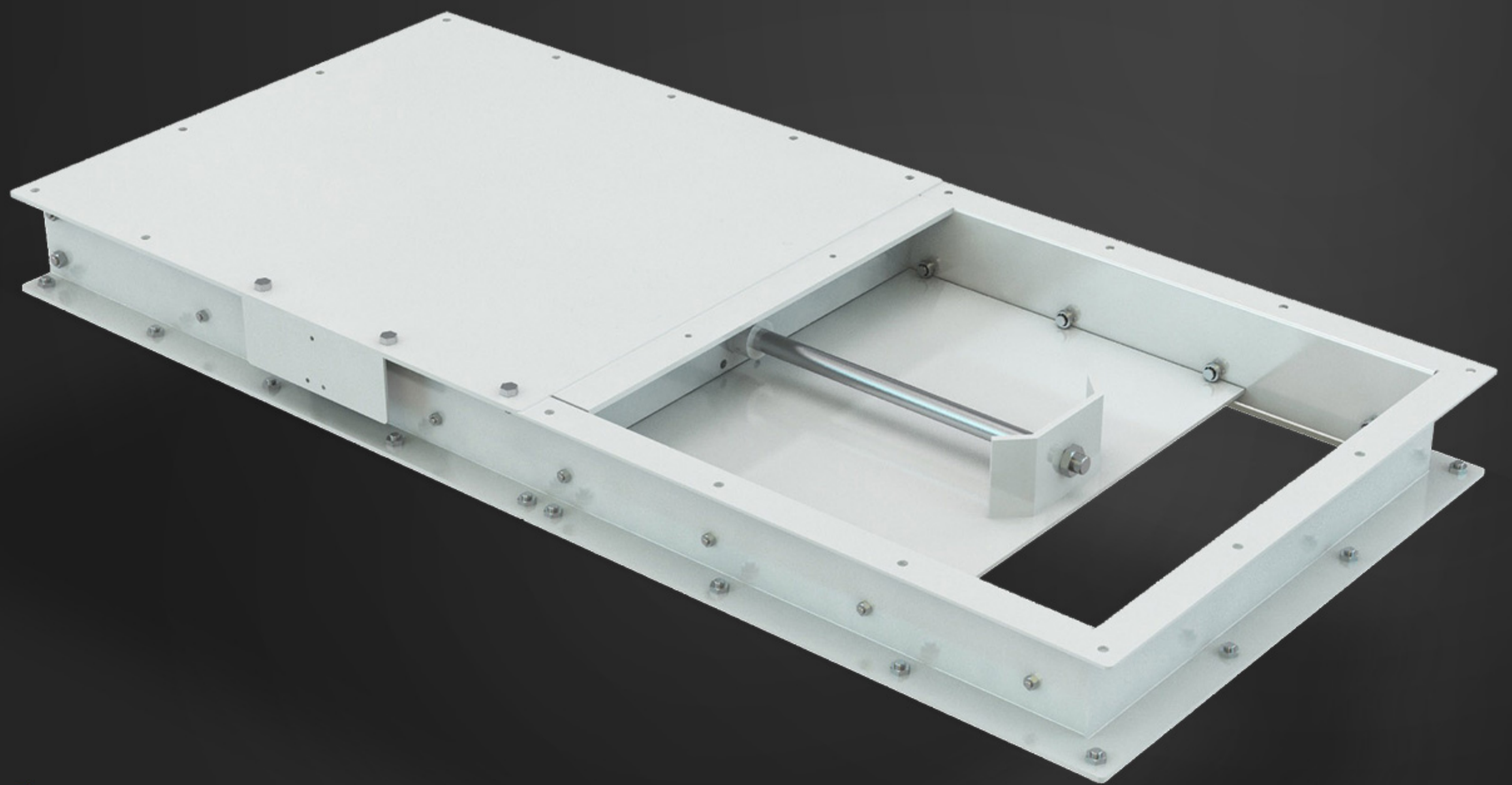

**ADVANCED  
SENSOR  
TECHNOLOGY**



HSMPKA

# SLIDING GATE

PORTE COULISSANTE

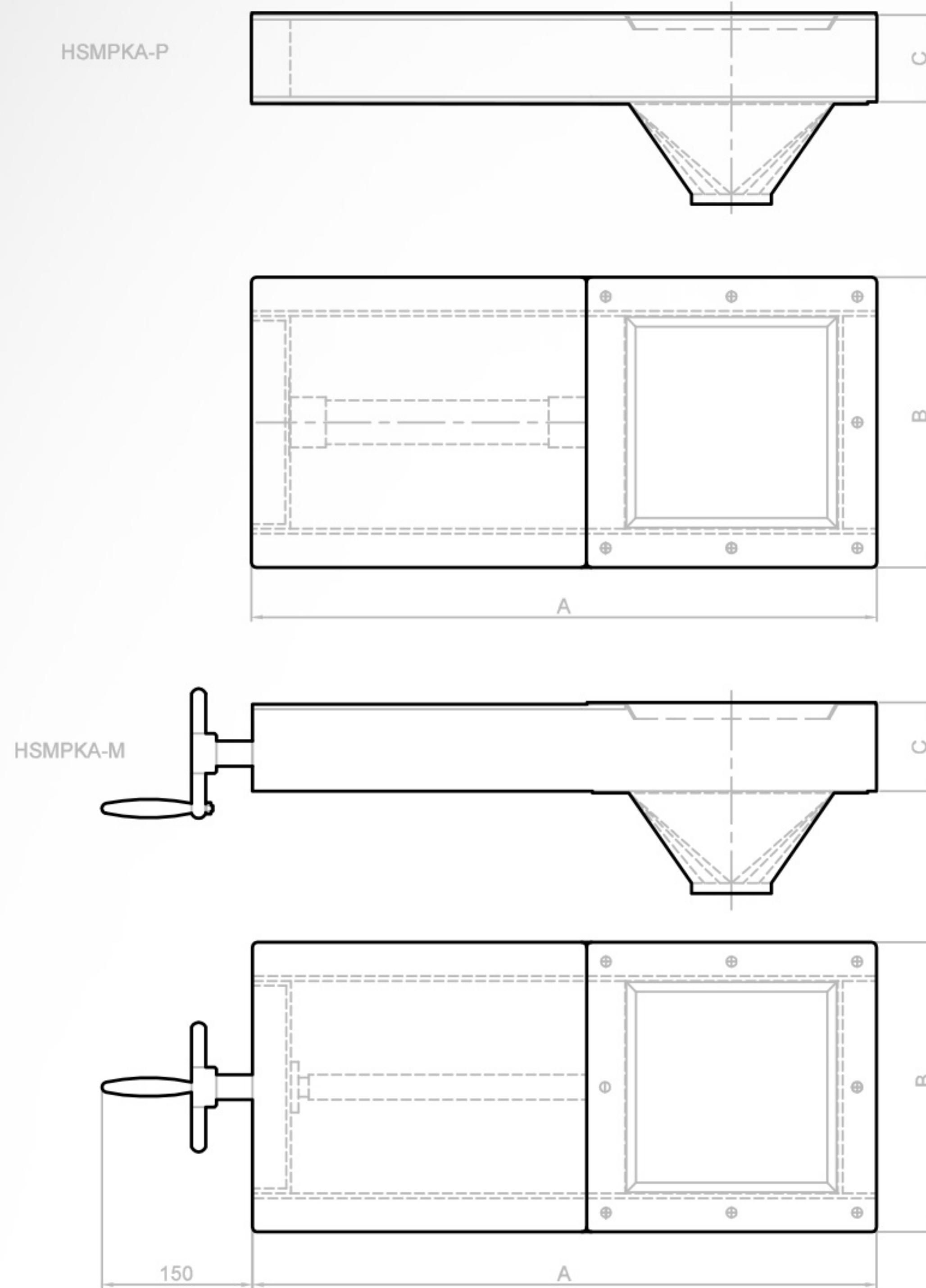

MODEL	DIMENSIONS mm.				TECHNICAL FEATURES		
	A	B	C	M	Weight Kg		Gross volume m³
					Net	Gross	
HSMPKA 170	515	250	90	170x170	23	40	0,1
HSMPKA 200	615	280		200x200	27	48	
HSMPKA 220	645	300		220x220	30	53	
HSMPKA 270	745	350		270x270	33	60	
HSMPKA 320	845	400		320x320	36	58	
HSMPKA 350	945	450	100	350x350	54	92	0,3
HSMPKA 400	995	480		400x400	68	110	