

HSPTBL

AUGER TYPE BRAN PACKAGING MACHINE

- Auger Type Bran Packaging Machine is used for the packaging process of low-density bulk products (bran, feed, by products, etc.).

The compression screw mechanism allows maximizing the packaging amount.

FEATURES

- High Capacity
- Hygenic Construction
- Compression Screw Mechanism
- Pneumatic Bag Spout Tightening System
- Fast and Precise Filling Operation



HSPTBL

AUGER TYPE BRAN PACKAGING

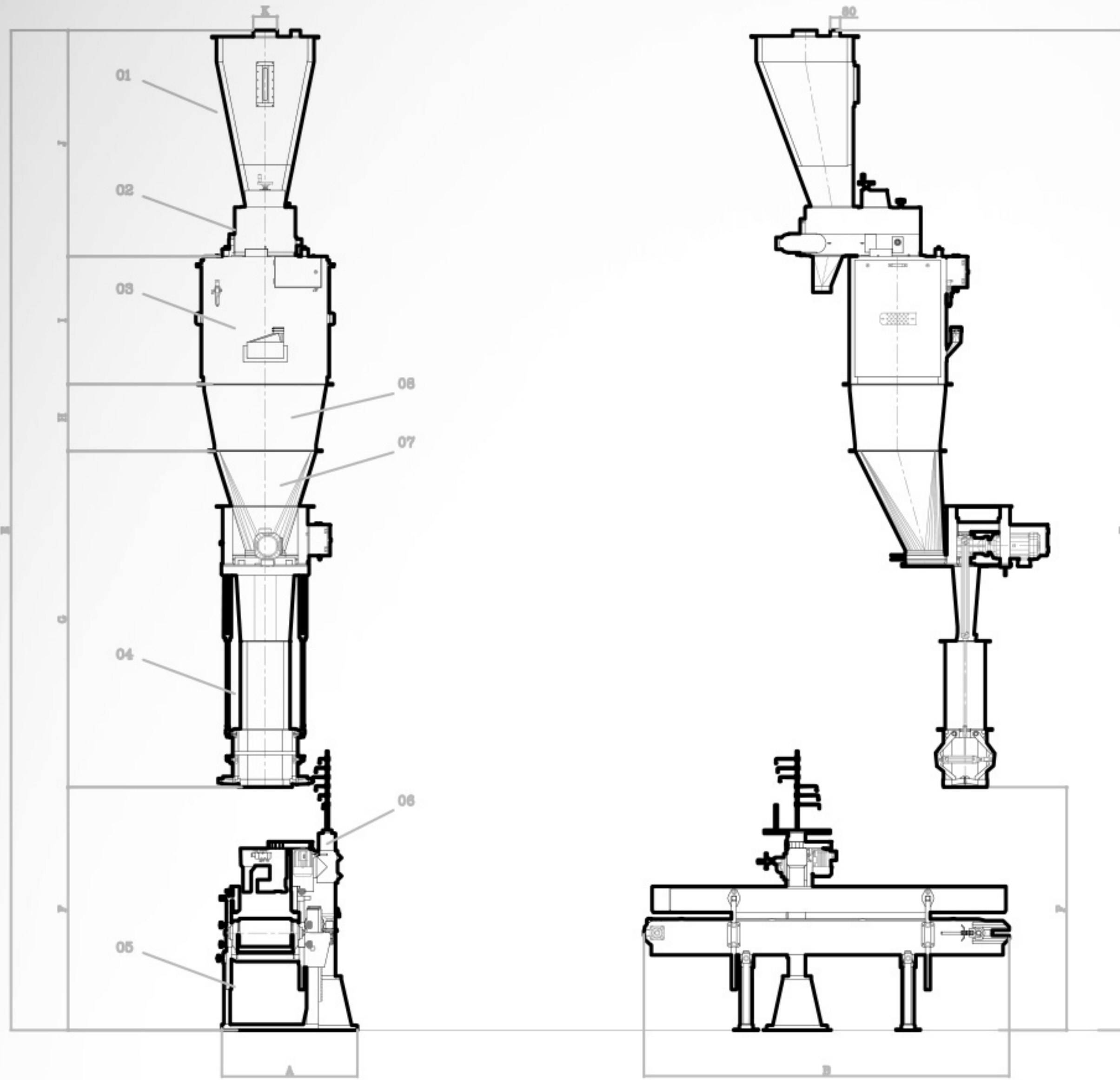

- 1- FEEDING BIN
- 2- FEEDING CONVEYOR
- 3- WEIGHING HOPPER
- 4- DISCHARGE SPOUT
- 5- OUTLET CONVEYOR
- 6- SEWING MACHINE (Optional)
- 7- FILLING BIN
- 8- FILLING BIN MOUTH (Variable According To The Distance)

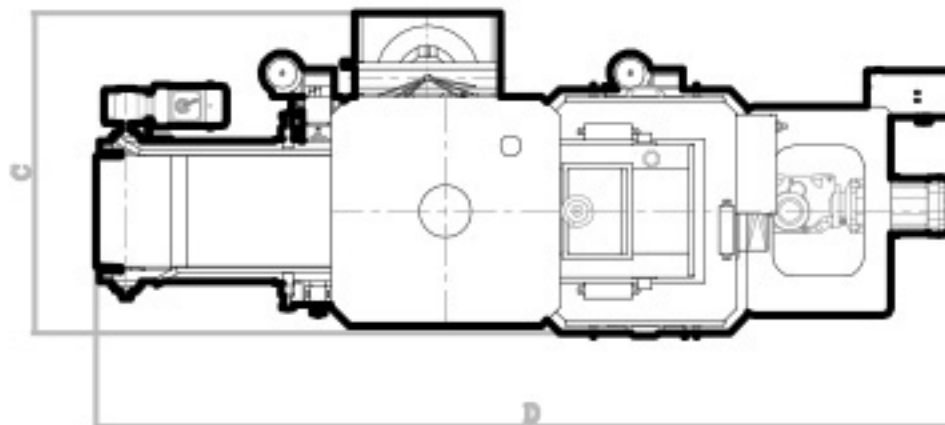

MODEL MODELE	DIMENSIONS mm.												TECHNICAL FEATURES				
	A	B	C	D	E	F	G	H	I	J	øK	øL	Capacity Bag Spout Number	Motor Power (Kw)	Weight kg		Gross Volume m³
															Net	Gross	
HSPTBL	1118	3000	1225	3332	8229	2000	2768	500	1050	1861	200	80	240	2.60	250	550	40